

Test: Primary 6 Science (Prelim) - Red Swastika (Y0)

Points: 35 points

Name: _____

Score: _____

Date: _____

Signature: _____

Select multiple choice answers with a cross or tick:

- Only select one answer
- Can select multiple answers

Question 1 of 61

Primary 6 Science (Prelim) 1 pt

The diagram below shows a tree.

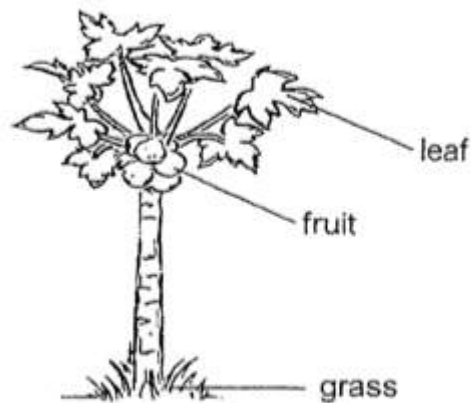

Which of the following statements about the tree is/are correct?

- A: It makes its own food.
B: It is a flowering plant.
C: It has a strong stem.

-
- A) B only
- B) A and C only
- C) B and C only
- D) A, B and C

Question 2 of 61

Primary 6 Science (Prelim)

1 pt

What is the similarity between mammals and reptiles?

- A) They have legs
- B) They live only on land
- C) They obtain food from other living things
- D) They have the same type of body covering

Question 3 of 61

Primary 6 Science (Prelim)

1 pt

Three identical slices of bread were put into three identical glass jars, X, Y and Z. The jars were placed in the Science room.

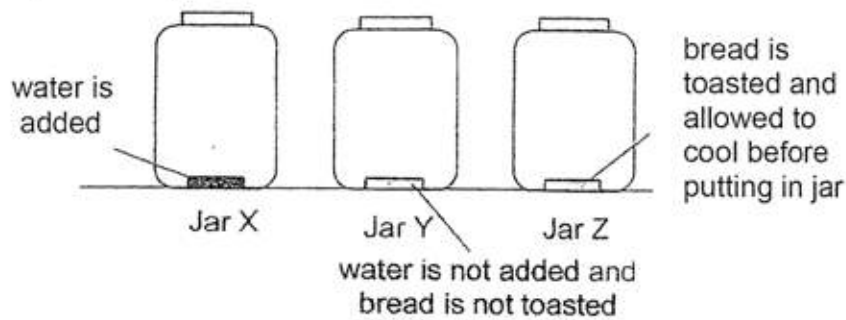

Which of the following shows the most likely observation after five days?

| | Bread is not mouldy | Bread is slightly mouldy | Bread is very mouldy |
|-----|---------------------|--------------------------|----------------------|
| (1) | Z | Y | X |
| (2) | Z | X | Y |
| (3) | Y | Z | X |
| (4) | Y | X | Z |

- A) 1
- B) 2
- C) 3
- D) 4

Question 4 of 61

Primary 6 Science (Prelim)

1 pt

Lynn created the set-ups shown below and left them in the classroom.

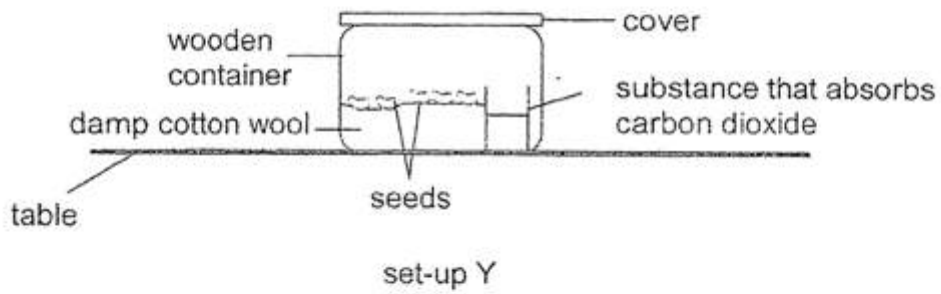
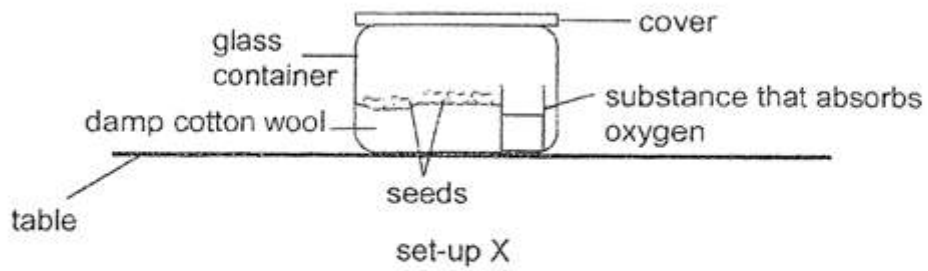

In which set-up(s) will the seeds germinate?

| | set-up X | set-up Y |
|-----|----------|----------|
| (1) | ✓ | ✓ |
| (2) | X | ✓ |
| (3) | ✓ | X |
| (4) | X | X |

- A) 1
 B) 2
 C) 3
 D) 4

Question 5 of 61

Primary 6 Science (Prelim)

1 pt

The diagrams below show the reproductive parts of a flower and a human.

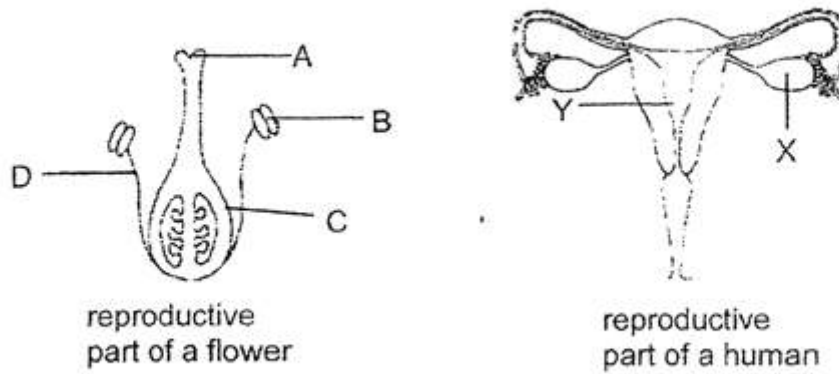

Which parts of the systems shown above have similar function?

-
- A) A and X only
 - B) B and Y only
 - C) C and X only
 - D) D and Y only

Question 6 of 61

Primary 6 Science (Prelim)

1 pt

Mr Tan has a farm growing both fruit trees and vegetables. He noticed that the leaves of his vegetables were damaged with holes by the young of insect K.

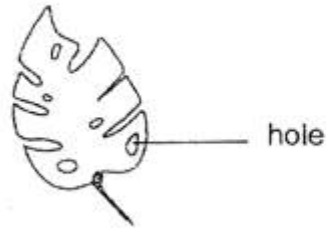

The adults of insect K only collect nectar from the flowers of the fruit trees in the farm and help to pollinate the flowers.

Mr Tan decided to spray pesticide on the leaves of his vegetables so that they will not be damaged.

Which of the following will likely be the result of the use of pesticide after some time?

- A: Less fruits will be collected.
- B: More fruits will be collected.
- C: Less vegetables will be collected.
- D: More vegetables will be collected.

-
- A) A only
 - B) D only
 - C) A and D only
 - D) B and C only

Question 7 of 61

Primary 6 Science (Prelim)

1 pt

Alex made two paper airplanes with different wingspan.

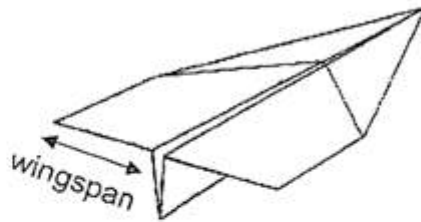

He released each airplane from the same height and location and recorded the results as shown in the table.

| | | |
|-------------------------------------------------|-------|-------|
| Length of wingspan | 4 cm | 8 cm |
| Time taken for the airplane to reach the ground | 8 s | 12 s |
| Distance travelled by the airplane | 32 cm | 55 cm |

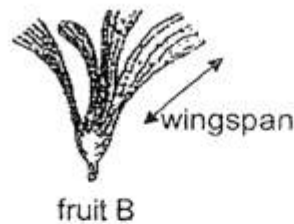
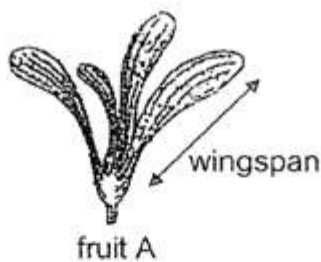

Alex found fruits A and B in a garden. Based on the above experiment, which young plant of the fruits is likely not to experience overcrowding?

| | Young plant of fruit | Reason |
|-----|----------------------|---------------------------------------------------------------------------|
| (1) | A | A has a longer wingspan and will travel a further distance away. |
| (2) | A | A has a longer wingspan and will take a shorter time to reach the ground. |
| (3) | B | B has a shorter wingspan and will travel a shorter distance away. |
| (4) | B | B has a shorter wingspan and will take a longer time to reach the ground. |

- A) 1
 B) 2
 C) 3
 D) 4

Question 8 of 61

Primary 6 Science (Prelim)

1 pt

The table below shows information on organisms M and N.

| Characteristic | organism M | organism N |
|--------------------------------------|------------|------------|
| Needs air, food and water to survive | ✓ | ✓ |
| Has a cell wall | ✓ | ✓ |
| Reproduces by spores | | ✓ |

Which of the following correctly represents organisms M and N?

| | Organism M | Organism N |
|-----|---------------------|---------------------|
| (1) | non-flowering plant | non-flowering plant |
| (2) | flowering plant | flowering plant |
| (3) | flowering plant | non-flowering plant |
| (4) | non-flowering plant | flowering plant |

-
- A) 1
- B) 2
- C) 3
- D) 4

Question 9 of 61

Primary 6 Science (Prelim)

1 pt

The diagram below shows a seedling. The arrows show the transportation of substance A and B inside the seedling.

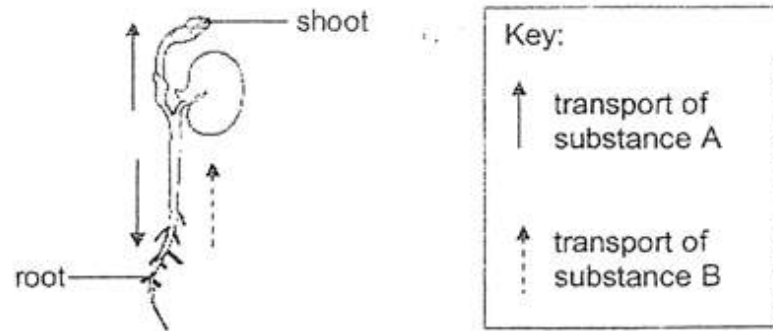

Based on the diagram, which of the following is correct?

| | substance A | substance B |
|-----|-------------|-------------|
| (1) | water | water |
| (2) | food | food |
| (3) | food | water |
| (4) | water | food |

- A) 1
 B) 2
 C) 3
 D) 4

Question 10 of 61

Primary 6 Science (Prelim)

1 pt

ups were

placed under a light source for one day.

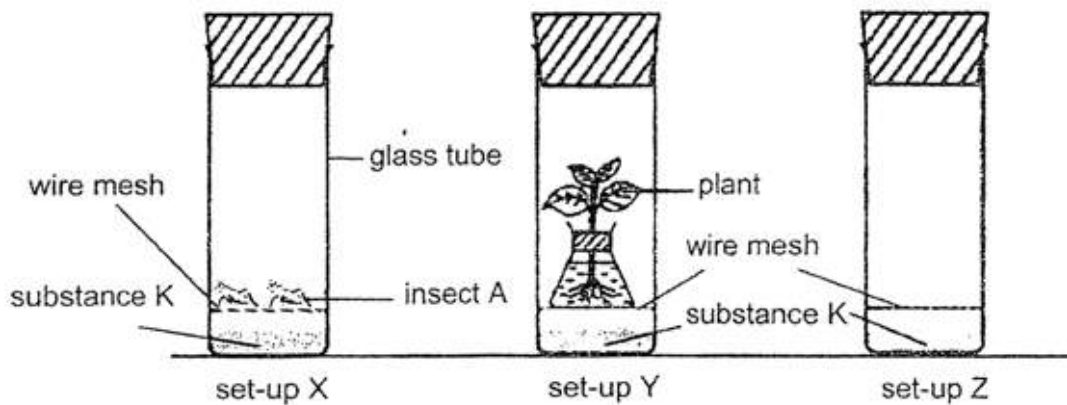

Substance K changes colour when there is a change in the amount of carbon dioxide as shown in the table below.

| amount of carbon dioxide | colour |
|--------------------------|--------|
| increase | yellow |
| remain the same | red |
| decrease | purple |

Based on the above set-ups, which of the following is correct at the end of one day?

| | set-up X | set-up Y | set-up Z |
|-----|----------|----------|----------|
| (1) | yellow | red | purple |
| (2) | purple | purple | red |
| (3) | yellow | yellow | red |
| (4) | yellow | purple | red |

- A) 1
 B) 2
 C) 3
 D) 4

Question 11 of 61

Primary 6 Science (Prelim)

1 pt

The diagram below shows the flow of blood in a human body.

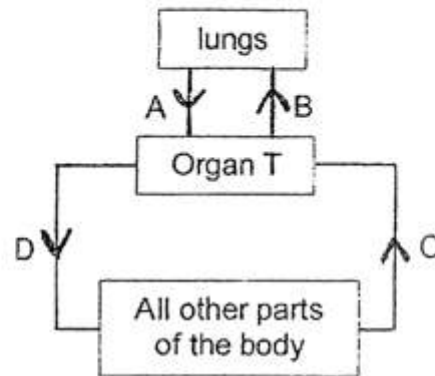

Based on the diagram above, which of the following is correct?

| | Organ T | Blood rich in oxygen | Blood rich in carbon dioxide |
|-----|---------|----------------------|------------------------------|
| (1) | heart | A and D | B and C |
| (2) | nose | B and D | A and C |
| (3) | heart | B and C | A and D |
| (4) | nose | A and C | B and D |

- A) 1
 B) 2
 C) 3
 D) 4

Question 12 of 61

Primary 6 Science (Prelim)

1 pt

The following takes place in plants when there is light.

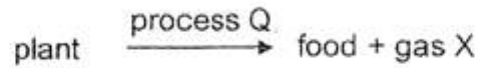

Identify process Q and gas X.

| | process Q | gas X |
|-----|------------------|----------------|
| (1) | germination | carbon dioxide |
| (2) | fertilisation | oxygen |
| (3) | pollination | carbon dioxide |
| (4) | photosynthesis | oxygen |

-
- A) 1
- B) 2
- C) 3
- D) 4

Question 13 of 61

Primary 6 Science (Prelim)

1 pt

Lina created the set-up shown below.

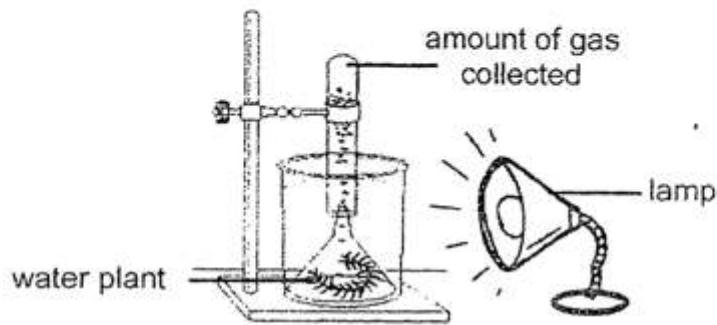

She measured the number of bubbles produced by the plant for one minute. She repeated the experiment with different values of X and recorded her observations in the table below.

| variable X (unit) | amount of gas collected (cm ³) |
|-------------------|--------------------------------------------|
| 15 | 32 |
| 25 | 27 |
| 35 | 18 |
| 45 | 9 |

Based on the information shown above, which of the following is variable X?

- A) light intensity
- B) number of leaves
- C) amount of carbon dioxide
- D) distance between the lamp and water plant

Question 14 of 61

Primary 6 Science (Prelim)

1 pt

The table below shows the organisms in a pond. Animal Y eats plant X only.

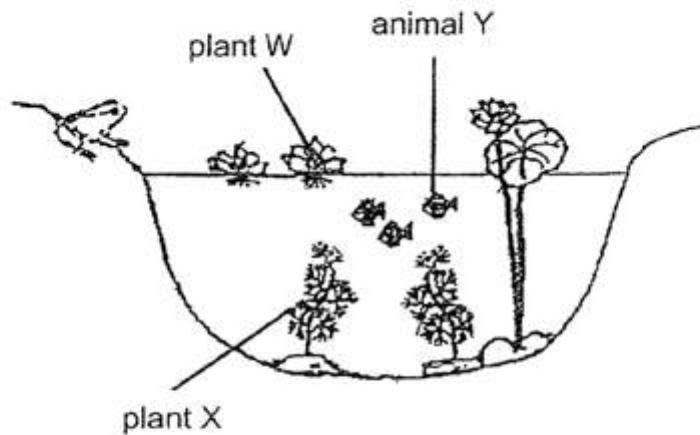

Plant W grew at a very fast rate and covered the surface of the pond within two weeks.

Which of the following graphs correctly shows the change in the number of animal Y after two months?

A)

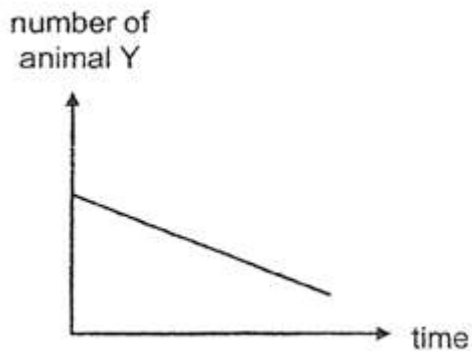

B)

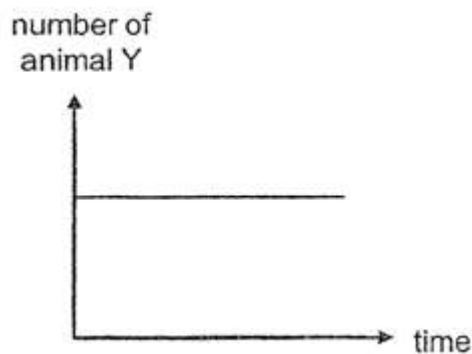

C)

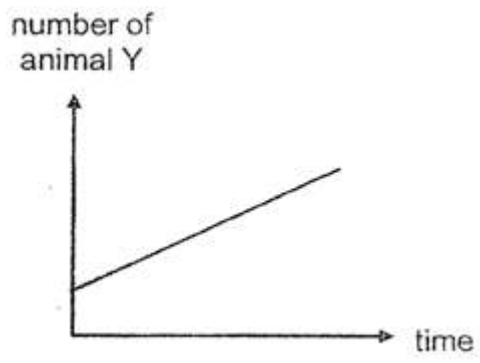

D)

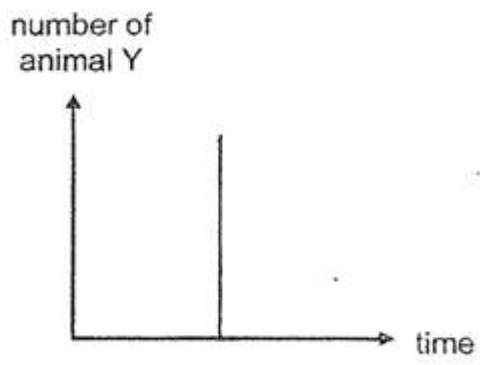

Question 15 of 61

Primary 6 Science (Prelim)

1 pt

The picture shows a camping tent. Part B is a window.

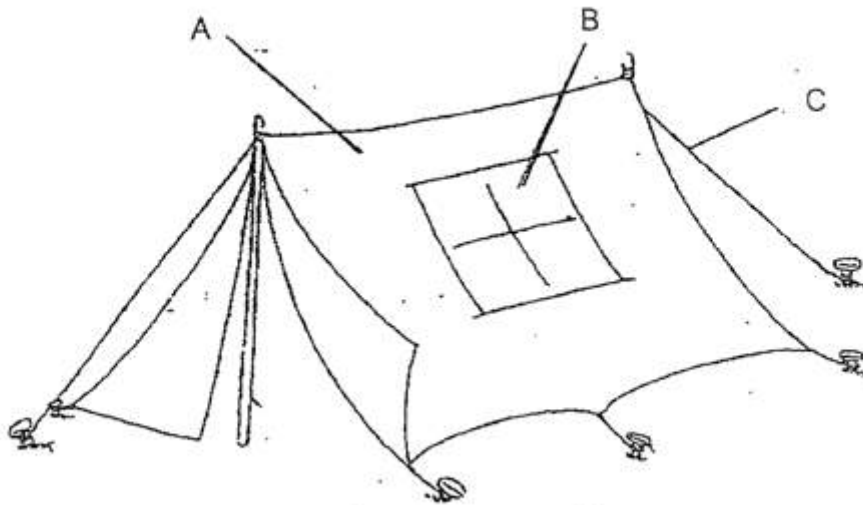

The table below shows the properties of four different materials, W, X, Y and Z.

| Material | Properties | | | |
|----------|------------|-------------|--------|----------|
| | waterproof | transparent | strong | flexible |
| W | ✓ | ✓ | | |
| X | ✓ | | ✓ | ✓ |
| Y | | | ✓ | ✓ |
| Z | | | ✓ | |

Which one of the following shows the most suitable material for parts A, B and C of the camping tent?

| | A | B | C |
|-----|---|---|---|
| (1) | W | X | Z |
| (2) | Z | W | X |
| (3) | X | W | Y |
| (4) | Y | Z | W |

- A) 1
 B) 2
 C) 3
 D) 4

Question 16 of 61

Primary 6 Science (Prelim)

1 pt

Study the diagram below carefully.

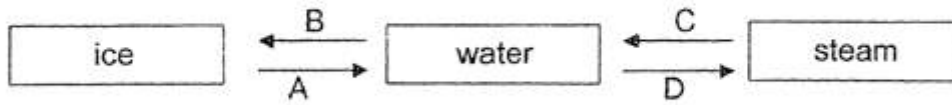

Which of the following shows heat loss during the processes?

- A) B only
- B) A and C only
- C) B and C only
- D) A and D only

Question 17 of 61

Primary 6 Science (Prelim)

1 pt

George filled two containers, A and B, with the same amount of water and placed them at two different locations. He measured the volume of water left in each container at regular intervals over some time and plotted the graph below.

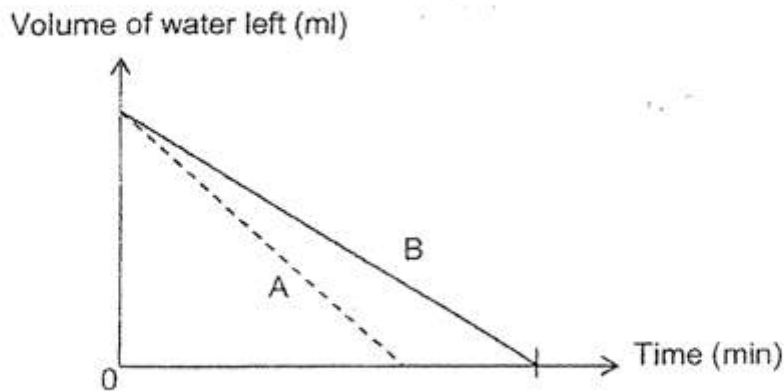

Based on the graph, which one of the following statement is most likely correct?

- A) container A was in a location with a higher temperature than container B
- B) container A has a smaller exposed surface area than container B
- C) container B has a larger exposed surface area than container A
- D) container B was in a location with a higher temperature than container A

Question 18 of 61

Primary 6 Science (Prelim)

1 pt

Three 500 cm³ conical flask, A, B and C are joined to an air pump as shown in the diagram below.

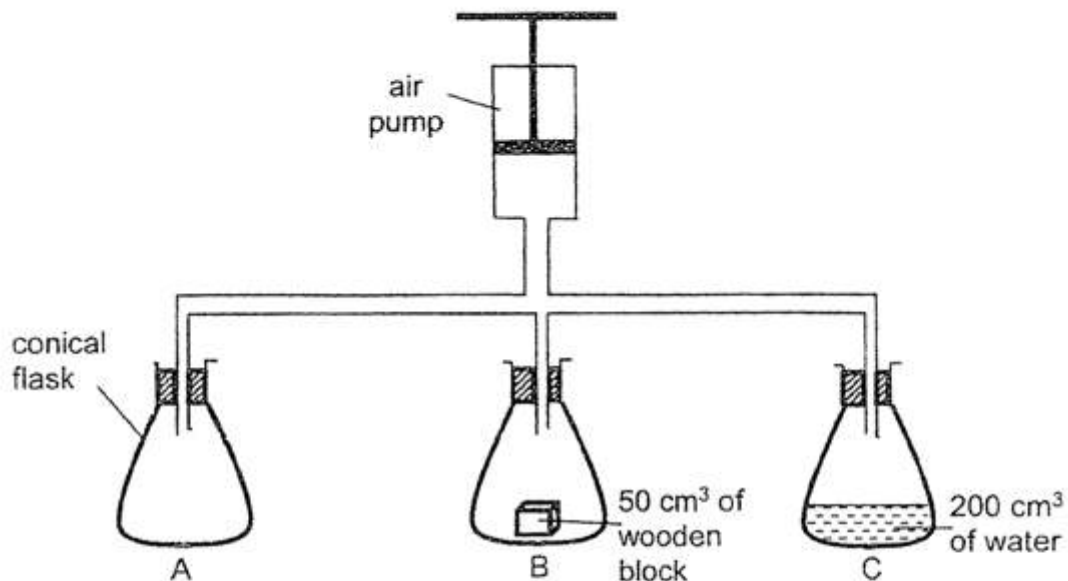

The handle of the air pump is pushed down three times, pushing in 50 cm³ of air with each pumping action.

What is the final volume of air in each flask at the end of the experiment?

| | Flask A (cm ³) | Flask B (cm ³) | Flask C (cm ³) |
|-----|----------------------------|----------------------------|----------------------------|
| (1) | 650 | 650 | 650 |
| (2) | 500 | 450 | 300 |
| (3) | 500 | 500 | 350 |
| (4) | 650 | 600 | 450 |

- A) 1
 B) 2
 C) 3
 D) 4

Question 19 of 61

Primary 6 Science (Prelim)

1 pt

Study the circuit below. Bulbs A and B are identical and the three batteries are identical. At the start, bulb A is unlit while bulb B is lit with a brightness of 10 units.

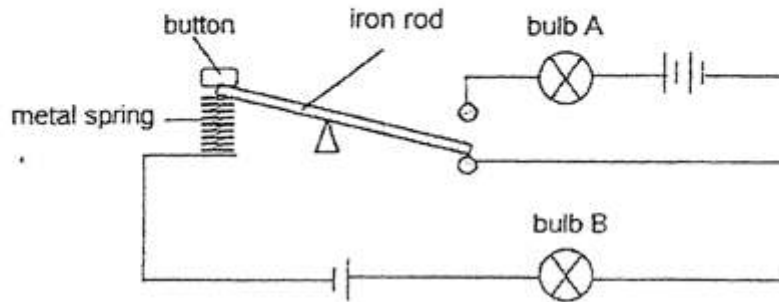

If the button is pressed and held down, what would happen to the brightness of bulbs A and B?

| | bulb A | bulb B |
|-----|--------------------|--------------------|
| (1) | more than 10 units | same as 10 units |
| (2) | will not light up | will not light up |
| (3) | more than 10 units | more than 10 units |
| (4) | will not light up | same as 10 units |

- A) 1
 B) 2
 C) 3
 D) 4

Question 20 of 61

Primary 6 Science (Prelim)

1 pt

The diagram below shows two circuits, A and B. Each of the circuit has a steel rod, a glass rod and a plastic rod which is represented by the black rectangles.

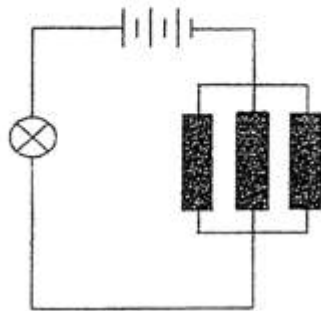

circuit A

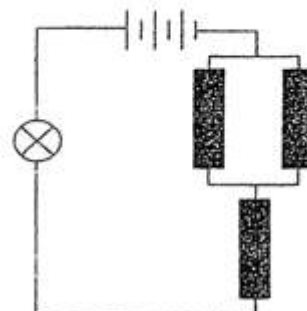

circuit B

Which observation is correct based on the above circuits?

| | bulb in circuit A | bulb in circuit B |
|-----|-------------------|-------------------|
| (1) | does not light up | does not light up |
| (2) | does not light up | lights up |
| (3) | lights up | does not light up |
| (4) | lights up | lights up |

- A) 1
 B) 2
 C) 3
 D) 4

Question 21 of 61

Primary 6 Science (Prelim)

1 pt

Ali constructed a game using two batteries and four light bulbs holder W, X, Y and Z. The wires were hidden behind the card.

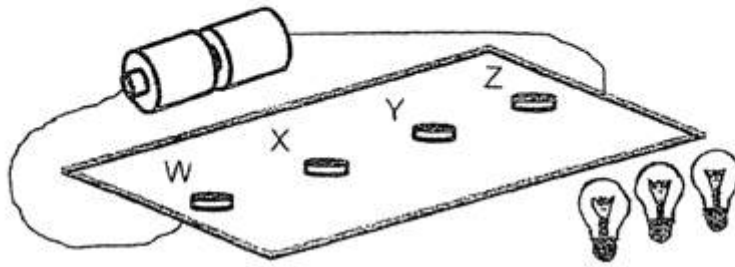

Ali tried to find out how W, X, Y and Z were connected using three identical light bulbs. His findings are as shown below.

| There is no bulb at | Findings |
|---------------------|---------------------------------------------|
| W | bulbs at holder X, Y and Z lit up |
| X | bulbs at holder W, Y and Z lit up |
| Y | bulbs at holder W, X and Z did not light up |
| Z | bulbs at holder W, X and Y did not light up |

Which of the following shows the correct circuit of the set-up.

A)

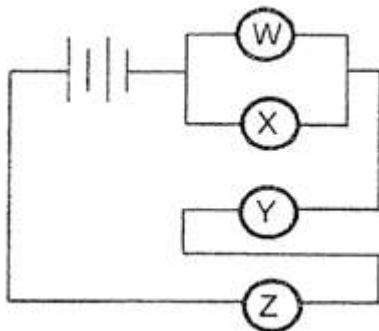

B)

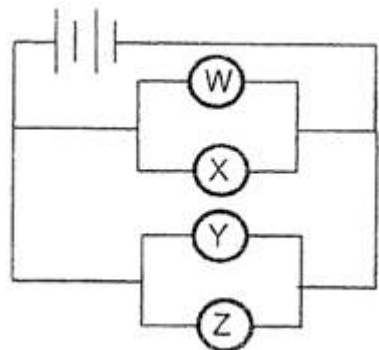

C)

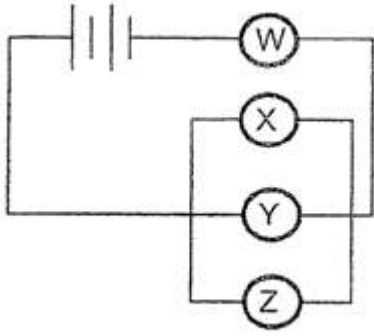

D)

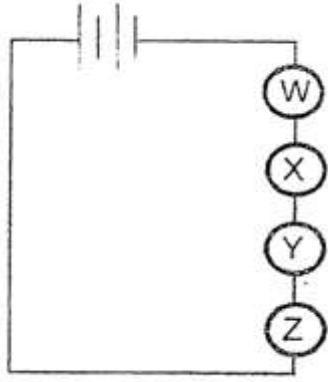

Question 22 of 61

Primary 6 Science (Prelim)

1 pt

Jane wants to find out whether the number of turns of the wire around the steel rod affects the strength of the electromagnet.

Which two set-ups below should she choose to conduct a fair test?

A

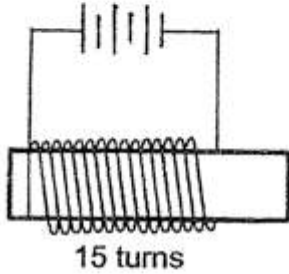

B

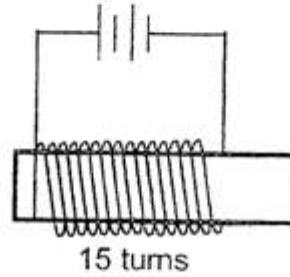

C

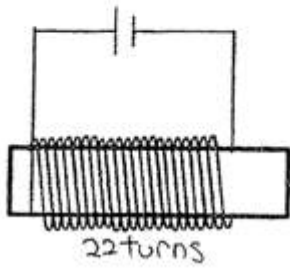

D

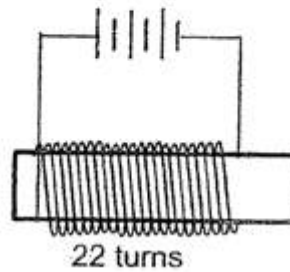

- A) A and C only
- B) A and D only
- C) B and C only
- D) B and D only

Question 23 of 61

Primary 6 Science (Prelim)

1 pt

The diagrams below show three examples of how forces are used.



A: playing a violin



B: sweeping the floor



C: making a fire by rubbing a stick onto a wooden board

Which of the example(s) involve(s) friction?

-
- A) A only
- B) C only
- C) B and C only
- D) A, B and C

Question 24 of 61

Primary 6 Science (Prelim)

1 pt

Alex releases a ball from the top of the ramp as shown below.

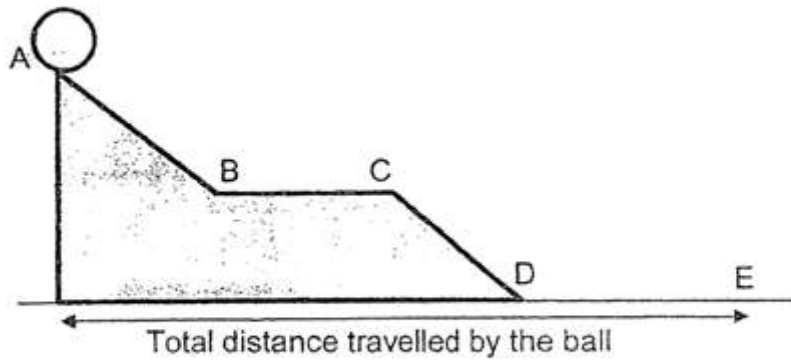

Which one of the following graph shows the gravitational force acting on the ball?

A)

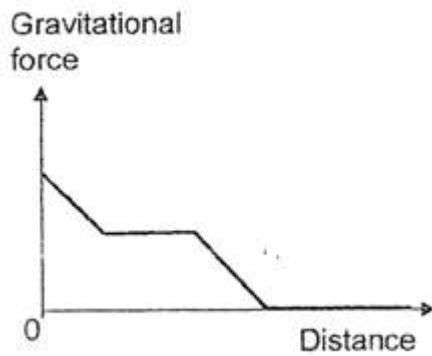

B)

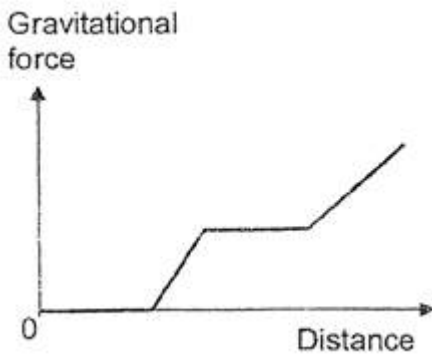

C)

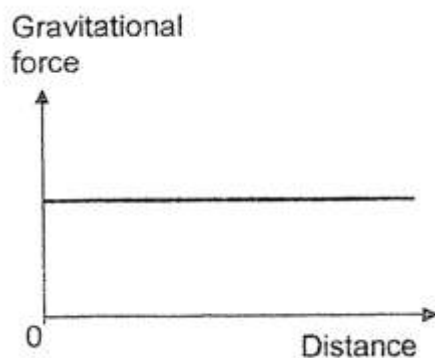

D)

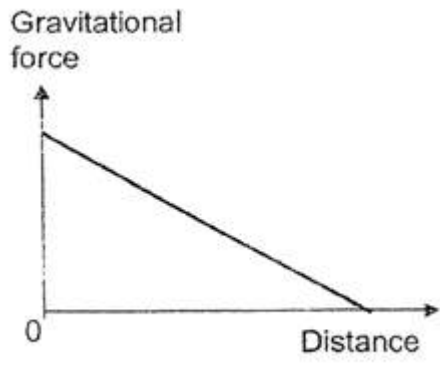

Question 25 of 61

Primary 6 Science (Prelim)

1 pt

Joyce set up three magnets AB, CD, EF and a steel bar GH as shown in the arrangement below.

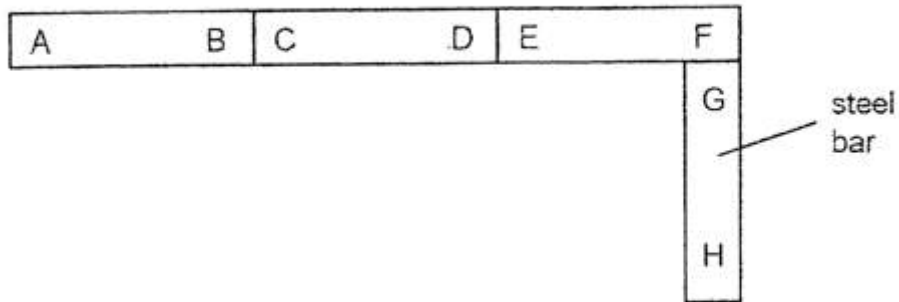

Which of the following is correct?

A)

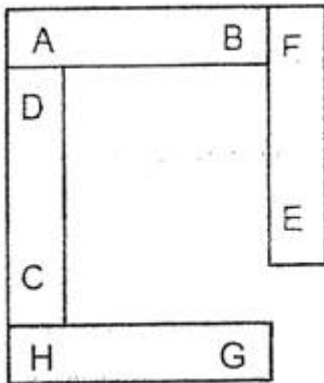

B)

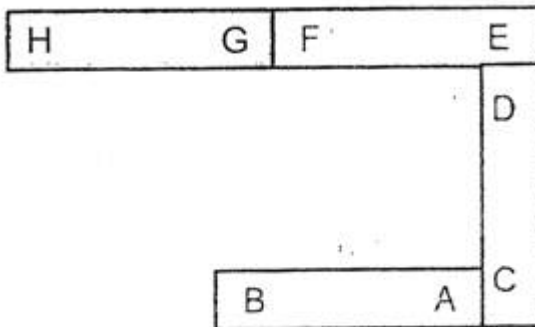

C)

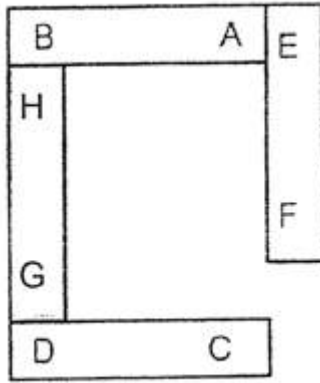

D)

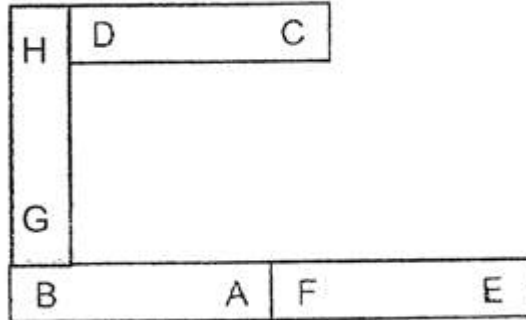

Question 26 of 61

Primary 6 Science (Prelim)

1 pt

Four identical beakers, filled with different amount of water of different temperatures, are used in an experiment to test the amount of heat in each of them.

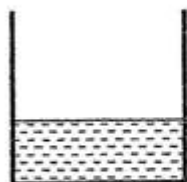

Beaker A
50ml of water
at 70°C

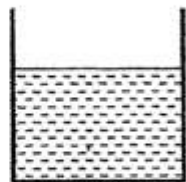

Beaker B
100ml of water
at 70°C

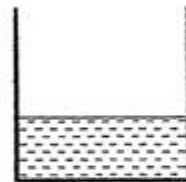

Beaker C
50ml of water
at 80°C

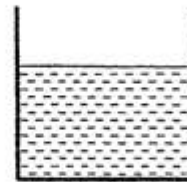

Beaker D
100ml of water
at 80°C

Which of the four beakers has the most amount of heat?

- A) Beaker A
- B) Beaker B
- C) Beaker C
- D) Beaker D

Question 27 of 61

Primary 6 Science (Prelim)

1 pt

Three materials of the same size, thickness and temperature were heated with the same heater. The time taken for the temperature of the three materials to increase by 10°C were recorded in the table shown.

| Material | Time taken to increase the temperature by 10°C (min) |
|----------|----------------------------------------------------------------------|
| X | 5 |
| Y | 2 |
| Z | 8 |

The materials were then used to make the following containers and pots. The same amount of hot water at 90°C was poured into each pot.

Which of the following set-ups would keep the water hottest for the longest time?

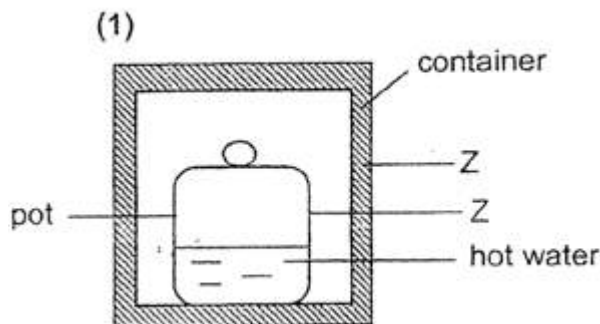
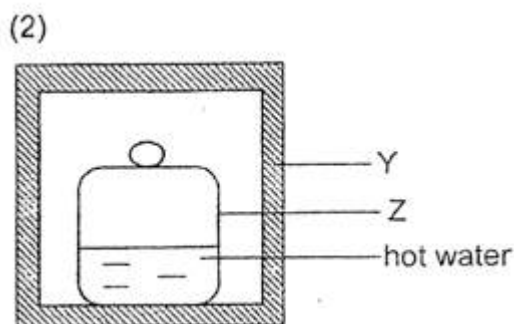
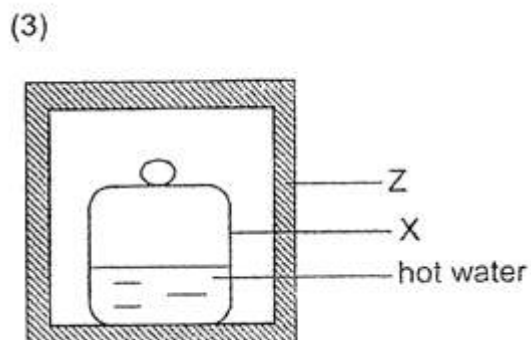
 A)

 B)

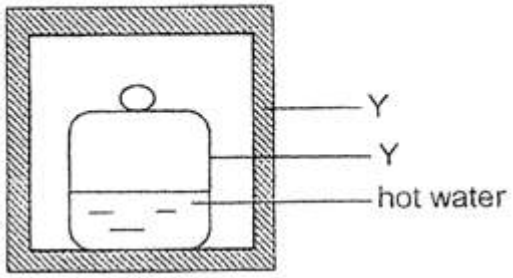
 C)

 D)

(4)



Question 28 of 61

Primary 6 Science (Prelim)

1 pt

The diagram below shows how the spring inside the weighing scale works when a person stands on it.

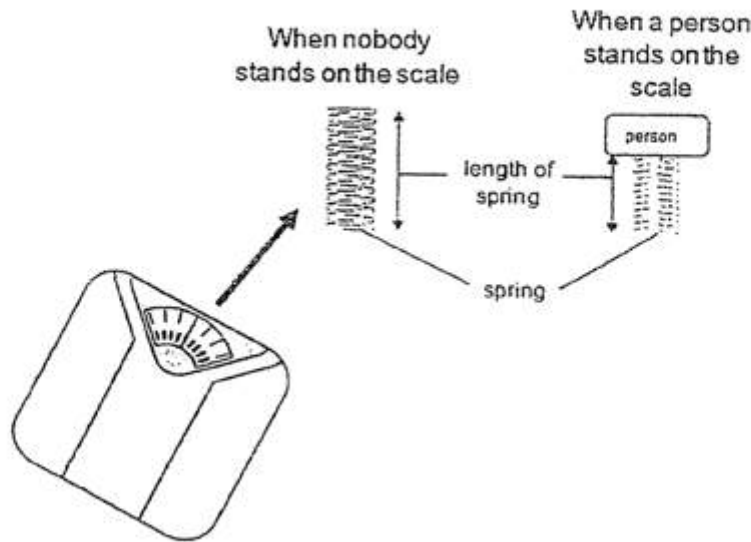

The table below shows the length of the spring when persons A, B and C stood on the weighing scale, one at a time.

| Person | Length of spring (mm) |
|--------|-----------------------|
| A | 10 |
| B | 5 |
| C | 16 |

Based on the information provided, which of the following is correct?

| | Person who caused the spring to have the most amount of elastic potential energy when he stepped on the weighing scale | Person with the most mass |
|-----|------------------------------------------------------------------------------------------------------------------------|---------------------------|
| (1) | B | B |
| (2) | B | C |
| (3) | C | A |
| (4) | C | B |

- A) 1
- B) 2
- C) 3
- D) 4

Question 29 of 61

Primary 6 Science (Prelim)

0 pts

Mr Wee is the owner of a fish farm. He observed that when the temperature of the water in the fish pond is higher, more of the fish died.

He conducted an experiment to measure the amount of oxygen in the water at different temperatures. His results are shown in the graph below.

Amount of oxygen in the water (units)

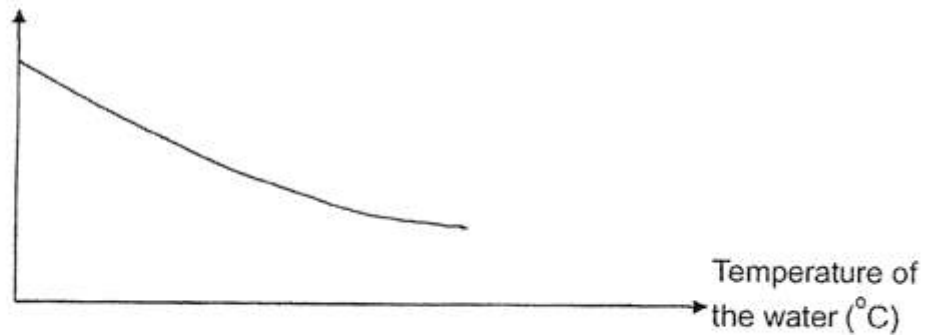

Based on the graph, what happens to the amount of oxygen in the water when the water is cooler? (1m)

Question 30 of 61

Primary 6 Science (Prelim)

0 pts

b) Mr Wee observed that the breathing rate of the fish increased as the temperature of the water increased. Using the results of his experiment, explain why.

Question 31 of 61

Primary 6 Science (Prelim)

0 pts

c) After Mr Wee grew some water plant in the fish pond, he observed that less fish died when the water temperature increased. Based on the experiment, why was this so?

Question 32 of 61

Primary 6 Science (Prelim)

1 pt

Mr Tan created two set-ups as shown below. Before the experiment, both leather shoes were kept in a cupboard for a long time and as a result, a dark patch grew on each shoe.

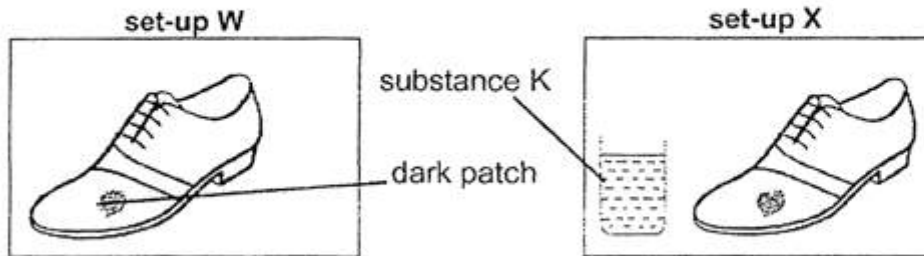

What was the dark patch that grew on both shoes? (1m)

Question 33 of 61

Primary 6 Science (Prelim)

0 pts

Mr Tan wanted to investigate if substance K can help remove the dark patch. Below is an instruction on how to use substance K.

Place substance K next to leather products with dark patches. The patches will disappear within five days!

After five days, Mr Tan was pleased to see that the dark patch on the shoe in set-up X was gone.

What did substance K remove from set-up X? Explain your answer. (2m)

Question 34 of 61

Primary 6 Science (Prelim)

1 pt

The diagram shows the development of a flower into a fruit.

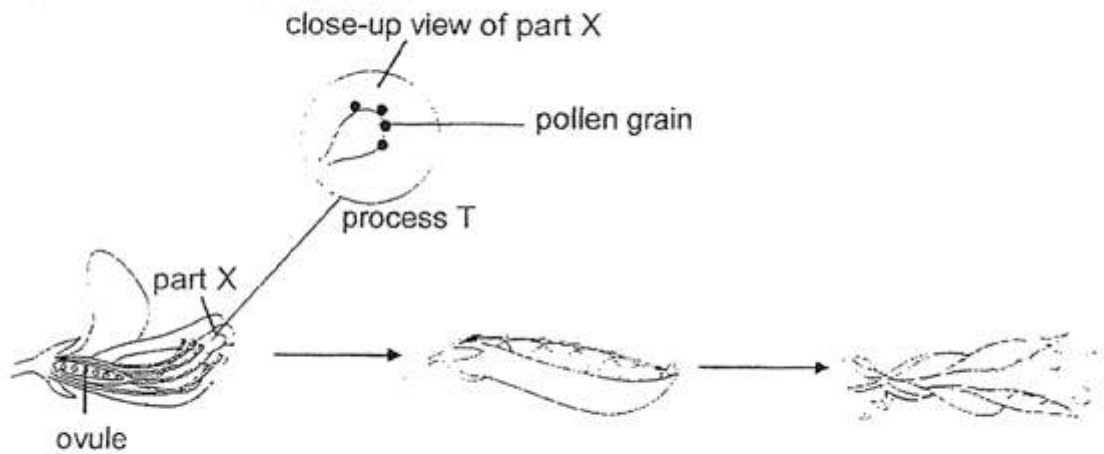

Base on the close-up view of part X, identify process T. (1m)

Question 35 of 61

Primary 6 Science (Prelim)

0 pts

Study the two flowers shown below.



On which flower(s) can process T take place? Explain your answer. (1m)

Question 36 of 61

Primary 6 Science (Prelim)

0 pts

Flower M shown below is found in the same location as flower L. There is no wind and there are bees flying around.

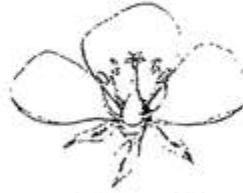

Flower M

| | Flower L | Flower M |
|------------------|----------|----------------|
| Colour of petals | dull | colourful |
| Scent | no smell | sweet-smelling |

Base on the information provided, which flower, L or M, has a higher chance of going through process T with the help of the bees?

Explain your answer. (2m)

Question 37 of 61

Primary 6 Science (Prelim)

1 pt

Jason conducted an experiment with three plants, X, Y and Z, as shown in the diagram. The plants were placed in a well-lit area and given the same amount of water daily.

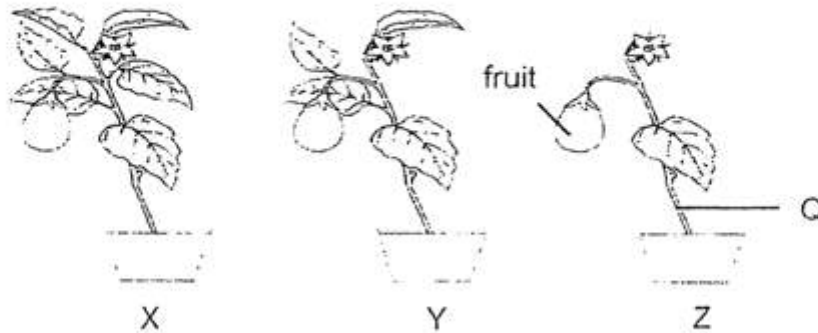

After some time, he measured the mass of the fruit in each set-up. The results are shown in the table below.

| Plant | Number of leaves on the plant | Mass of fruit (g) | |
|-------|-------------------------------|---------------------|-------------------|
| | | Start of experiment | End of experiment |
| X | 6 | 8 | 18 |
| Y | 4 | 8 | P |
| Z | 1 | 8 | 10 |

Based on the table, state a possible value for P. (1m)

Question 38 of 61

Primary 6 Science (Prelim)

1 pt

If all the leaves in plant X are removed, would the mass of the fruit for plant X increase, decrease or remain the same after some time?

- A) increase
- B) decrease
- C) remain the same

Question 39 of 61

Primary 6 Science (Prelim) 0 pts

c) Insect E is a pest which eats its way into Part Q of plant X. Explain how this affected the growth of the roots in plant Z

Question 40 of 61

Primary 6 Science (Prelim) 0 pts

Jia Hao created the set-up shown below. He placed two plants in containers A and B and filled all three containers with the same amount of water.

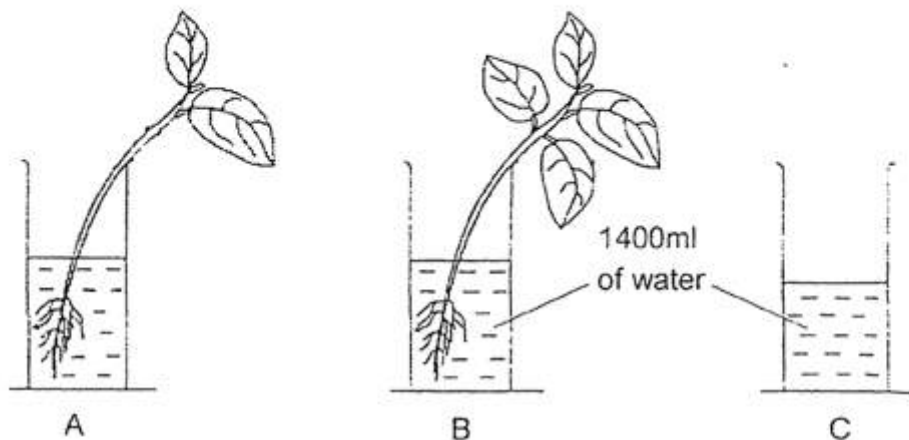

The three set-ups were placed in the garden for five days.

The table below shows the amount of water in the measuring cylinders at the start and at the end of the experiment.

| Day | Set-up A (ml) | Set-up B (ml) | Set-up C (ml) |
|-------|---------------|---------------|---------------|
| Day 1 | 1400 | 1400 | 1400 |
| Day 5 | 1200 | 1150 | 1300 |

Jia Hao concluded that the plant in set-up B took in 250ml of water. Explain whether his conclusion is correct. (1m)

Question 41 of 61

Primary 6 Science (Prelim) 0 pts

b) Jia Hao would like to find out if the presence of roots would affect the amount of water taken in by the plant using Set-up A and B.

What are the two changes he must do to the plant in set-up B in order to conduct a fair test?

Question 42 of 61

Primary 6 Science (Prelim) 0 pts

A leaf has tiny openings on its surface as shown in the diagram below. The tiny openings allows gaseous exchange to take place for the plant.

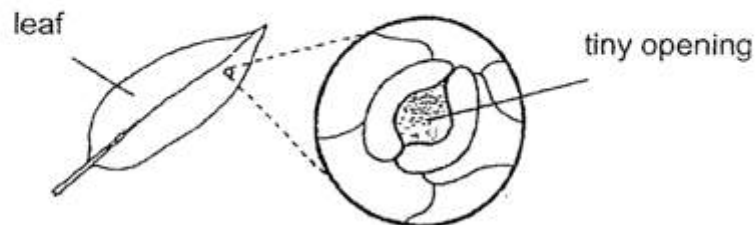

Jane measured the changes in the size of the tiny openings of some leaves on a plant. The plant was placed in the school field for a day. She recorded her results in the table below.

| Time | 4am | 8am | 12pm | 4pm | 8pm |
|-------------------------------------------|-----|-----|------|-----|-----|
| Average size of the tiny openings (units) | 1 | 3 | 5 | 3 | 1 |

Based on the table, how did the size of the tiny openings change from 4am to 12pm? (1m)

Question 43 of 61

Primary 6 Science (Prelim) 0 pts

What is the advantage and disadvantage to the plant when the size of the tiny openings are bigger?

Question 44 of 61

Primary 6 Science (Prelim)

0 pts

Which human body system has a similar function as the tiny openings on the leaf?

Question 45 of 61

Primary 6 Science (Prelim)

0 pts

Andy set up the experiment as shown below. He placed the set-up in a dry place.

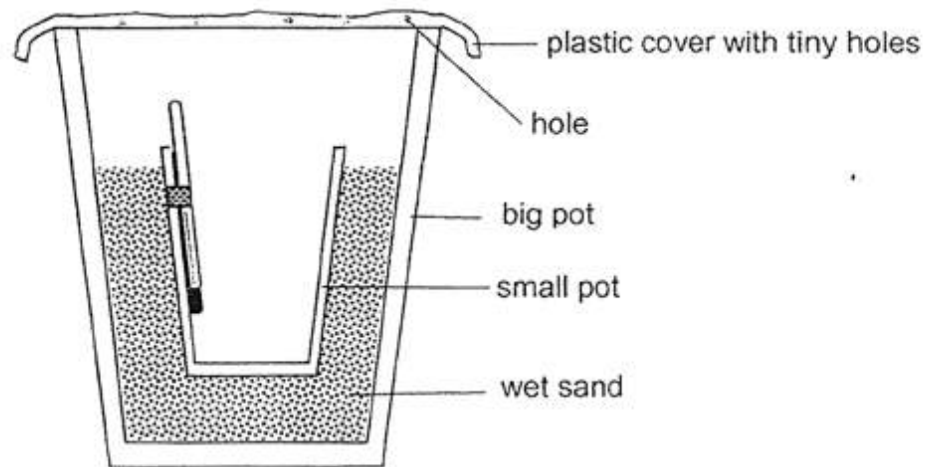

(a) What will be formed under the plastic sheet after some time? (1m)

Question 46 of 61

Primary 6 Science (Prelim)

0 pts

b) He noticed that there is a drop in the temperature of the air inside the small pot. Explain why

Question 47 of 61

Primary 6 Science (Prelim) 0 pts

c) After several hours, he noticed some water collected at the bottom of the small pot. Without changing the set-up, suggest one way to increase the amount of water collected in the small pot.

Question 48 of 61

Primary 6 Science (Prelim) 0 pts

May constructed circuit A, as shown below. All the bulbs lit up in circuit A.

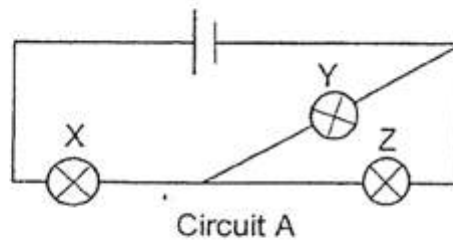

- (a) May removed one of the bulbs from circuit A and the other two bulbs did not light up. Which bulb did May remove? Explain your answer. (2m)
-

Question 49 of 61

Primary 6 Science (Prelim)

0 pts

- (b) May wanted to rearrange bulbs X, Y and Z, such that when one of the bulbs is fused, the remaining two bulbs will continue to light up. Complete the circuit diagram to show this new arrangement. (1m)

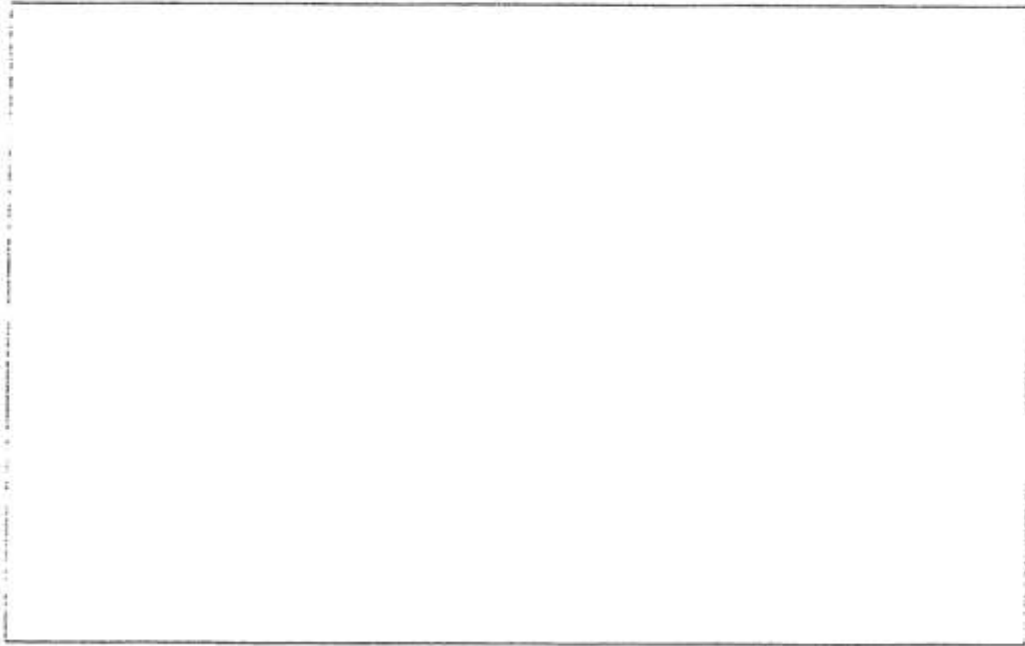

Question 50 of 61

Primary 6 Science (Prelim)

1 pt

The diagram below shows a model that can detect the amount of water in a storage system. When the amount of water reaches a certain level, the alarm sounds to alert that the storage system is full.

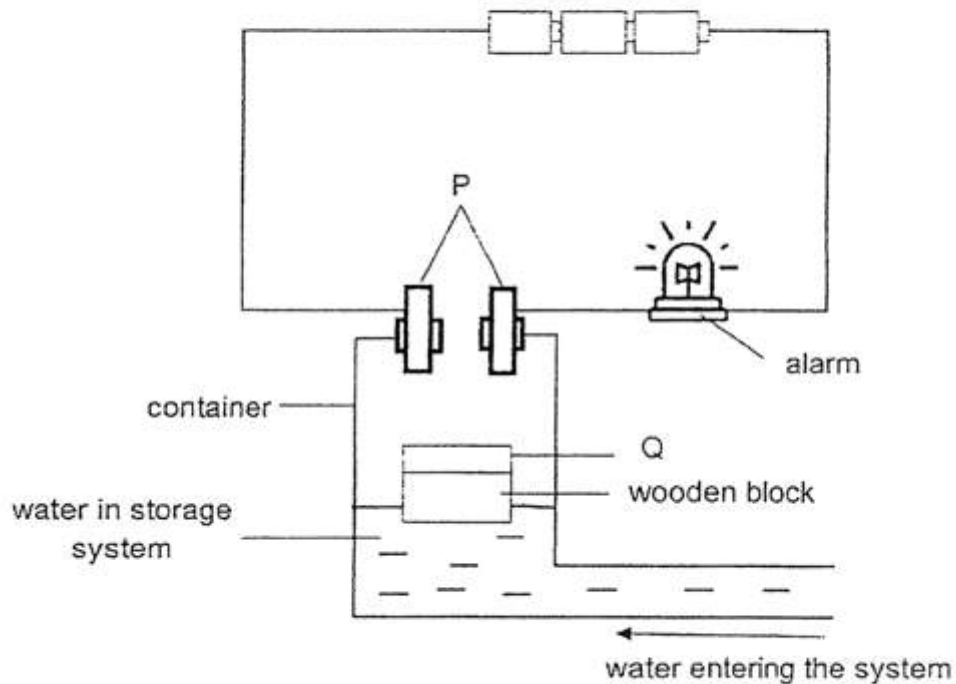

(c) What material must part P and Q be made of? (1m)

Question 51 of 61

Primary 6 Science (Prelim)

1 pt

d) Explain the answer for part (c)

Question 52 of 61

Primary 6 Science (Prelim)

0 pts

Joe set up an experiment as shown below. He pulled the box up the plank using a spring balance. He repeated the experiment using different values of the angle.

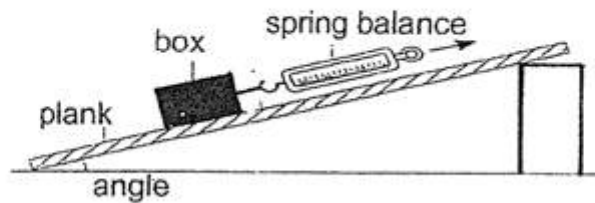

He plotted a line graph to show the results of the experiment.

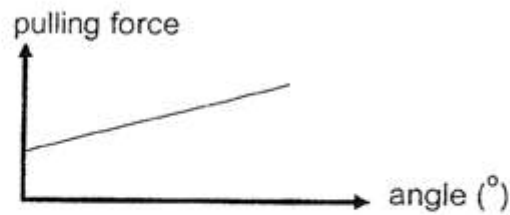

- (a) What is the relationship between the angle and the pulling force needed? (1m)

Question 53 of 61

Primary 6 Science (Prelim)

0 pts

Joe wanted to push a box up a plank to the back of a truck as shown below.

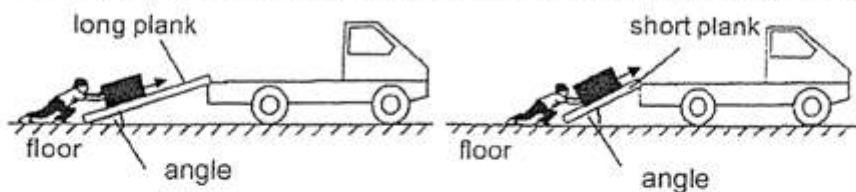

The table below shows the values of the angles.

| | long plank | short plank |
|--------------------|------------|-------------|
| Value of angle (°) | 40 | 60 |

- (b) Based on the graph and table, why it is a disadvantage to push the box up the truck using the short plank? Explain in terms of forces. (2m)

Question 54 of 61

Primary 6 Science (Prelim)

1 pt

18. David studied how the car park barrier operates using the circuit as shown. When he closed the switch, the weight moved downwards and touch rod X causing the car park barrier to rise.

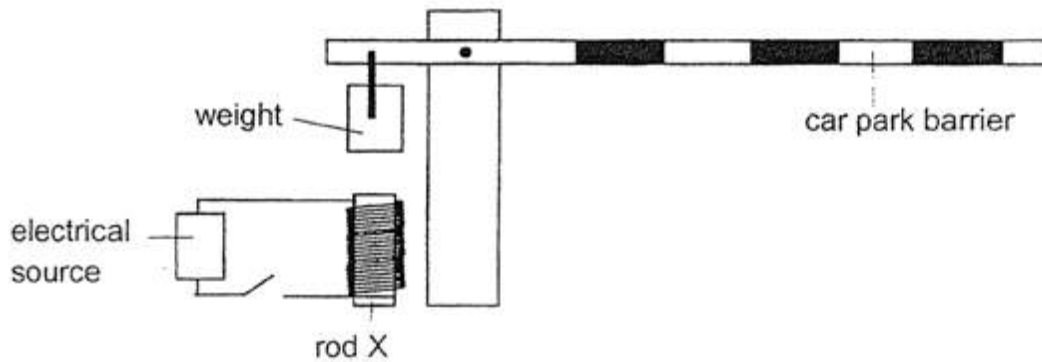

- (a) For the carpark barrier to work, give an example of a metal that the weight can be made of. (1m)
-

Question 55 of 61

Primary 6 Science (Prelim)

0 pts

- b) Explain why the weight touched rod X after David closed the switch
-

Question 56 of 61

Primary 6 Science (Prelim)

0 pts

A heat camera can show different temperatures. Each number is represented by a different shade of colour.

| Temperature (°C) | 21-30 | 31-40 | 41-50 | 51-60 | 61-70 | 71-80 |
|------------------|-------|-------|-------|-------|-------|-------|
| Colour | 1 | 2 | 3 | 4 | 5 | 6 |

Harry was given 4 cups of water, W, X, Y and Z. When he viewed the water in the cups through the heat camera, the following colours were observed.

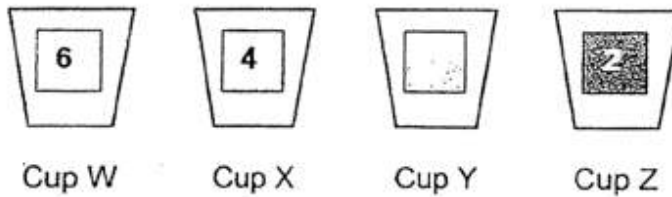

- (a) State the possible temperatures of water in the four cups in the table below. (1m)

| Cup W | Cup X | Cup Y | Cup Z |
|-------|-------|-------|-------|
| | | | |

Question 57 of 61

Primary 6 Science (Prelim)

0 pts

Harry placed a metal bar in a container of hot water at 70°C. When viewed through the heat camera, the following colours were observed on the metal bar.

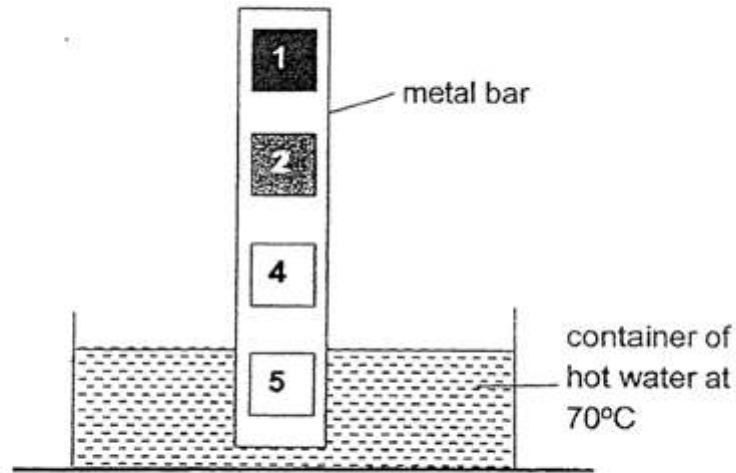

- (b) Based on the above diagram, explain why different colours were observed on the metal bar. (1m)

Question 58 of 61

Primary 6 Science (Prelim)

0 pts

An hour later, when viewed through the heat camera, only one colour was observed on the metal bar.

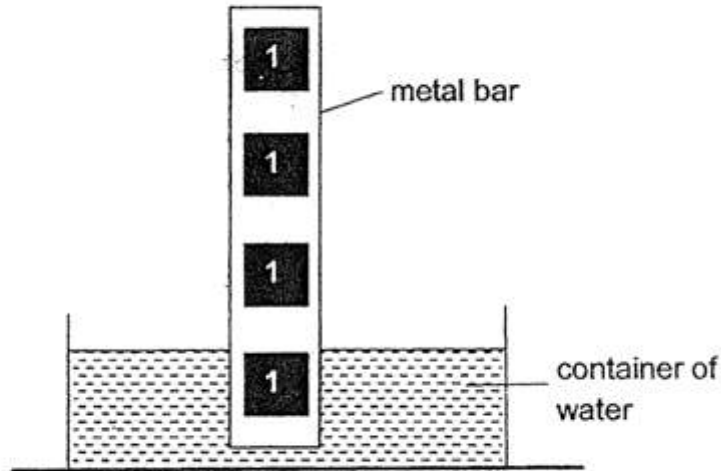

(c) Explain why only one colour was observed after an hour. (1m)

Question 59 of 61

Primary 6 Science (Prelim)

0 pts

A steamer uses steam to cook vegetables. The steam forms when the water in part C boils.

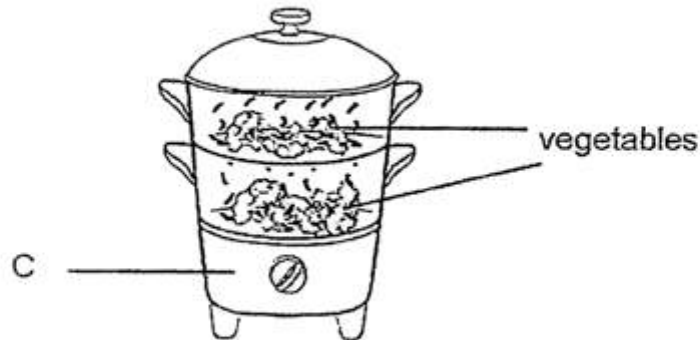

(a) What is the state of matter for steam? (1m)

Question 60 of 61

Primary 6 Science (Prelim) 0 pts

b) Explain why keeping the cooked vegetables in a glass container will keep it warm for a longer period of time

Question 61 of 61

Primary 6 Science (Prelim) 0 pts

The table below shows the minimum temperature needed for cooking different types of food so that it is safe to eat.

| Type of food | Minimum cooking temperature (°C) |
|--------------|----------------------------------|
| X | 92 |
| Y | 85 |
| Z | 80 |

- (c) Mrs Ong said that the three types of food can be cooked in a steamer until it is safe to eat. Based on the table, explain why she is correct. (2m)
-